

(No Model.)

4 Sheets—Sheet 1.

D. FRASER.

MACHINERY FOR SHAPING HEADS OF WOODEN CLUBS.

No. 542,246.

Patented July 9, 1895.

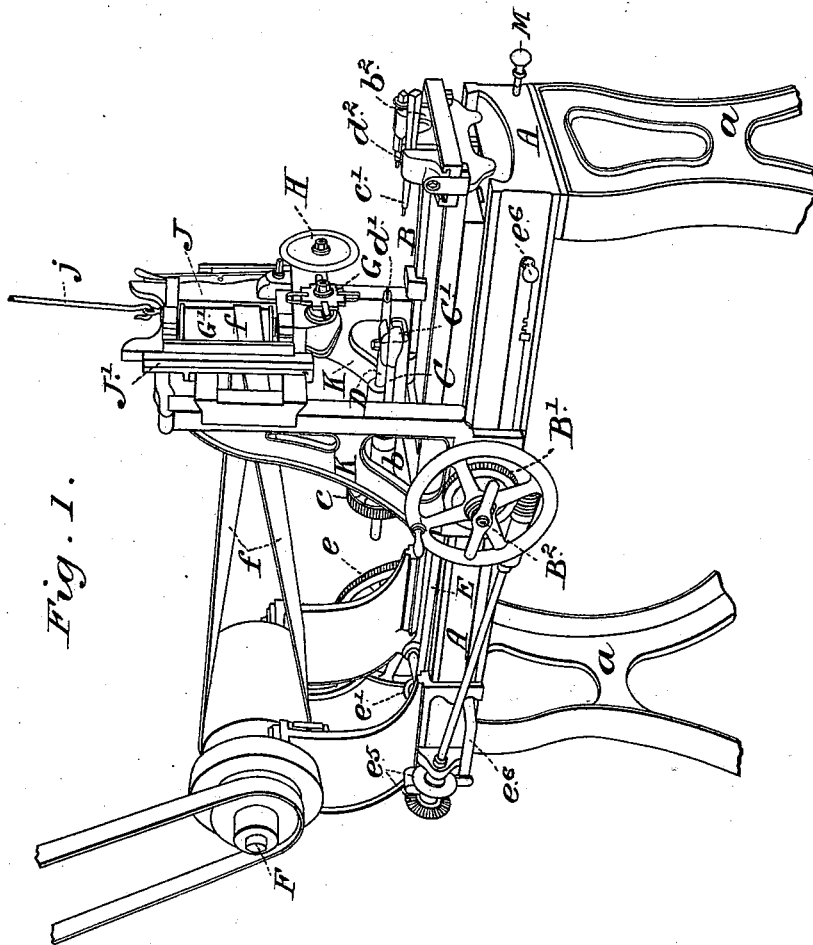

Fig. 1.

Witnesses
W. V. Bidgood
Edmond Cox

Inventor.
Daniel Fraser
By *[Signature]*
Atty.

(No Model.)

4 Sheets—Sheet 2.

D. FRASER.

MACHINERY FOR SHAPING HEADS OF WOODEN CLUBS.

No. 542,246.

Patented July 9, 1895.

Fig. 2.

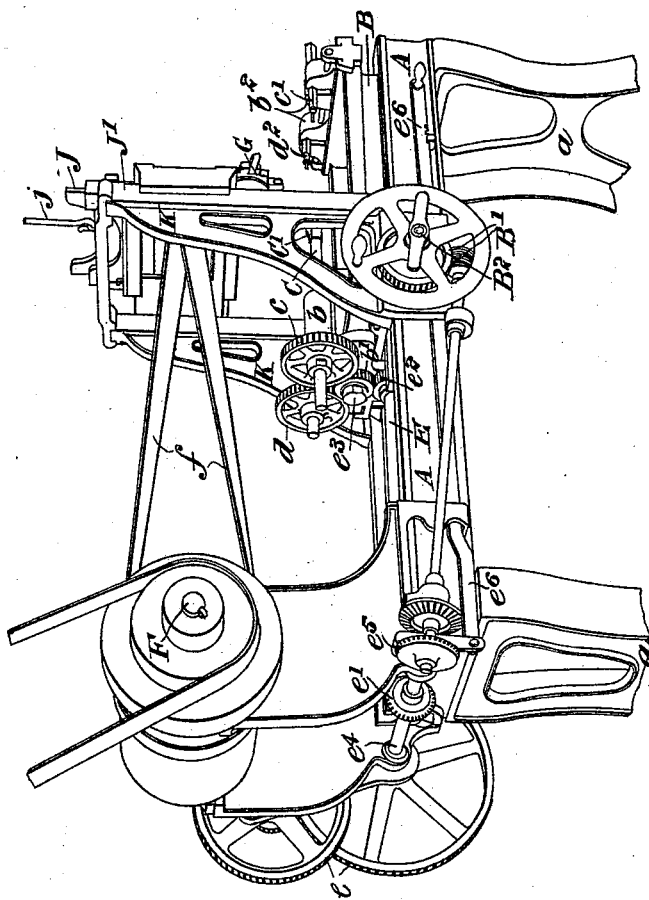

Witnesses
W. V. Bidgood
Edward L. Cox

Inventor.
Daniel Fraser
By Wm. J. Bidgood
Attys.

(No Model.)

4 Sheets—Sheet 3.

D. FRASER.

MACHINERY FOR SHAPING HEADS OF WOODEN CLUBS.

No. 542,246.

Patented July 9, 1895.

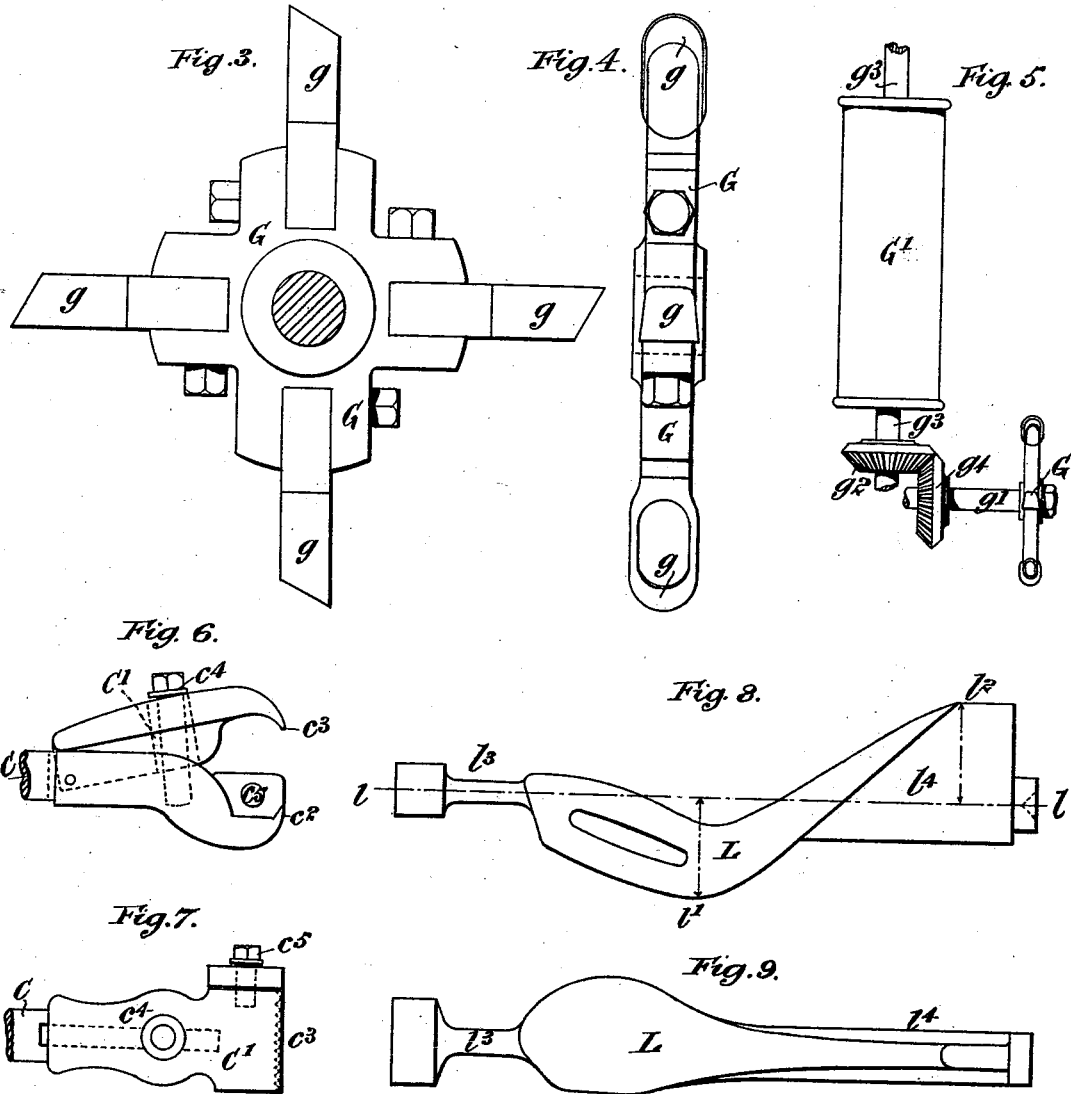

Witnesses
M. V. Bidgood
Edward L. Cox

Inventor,
Daniel Fraser
By *[Signature]*
Attorney

(No Model.)

4 Sheets—Sheet 4.

D. FRASER.

MACHINERY FOR SHAPING HEADS OF WOODEN CLUBS.

No. 542,246.

Patented July 9, 1895.

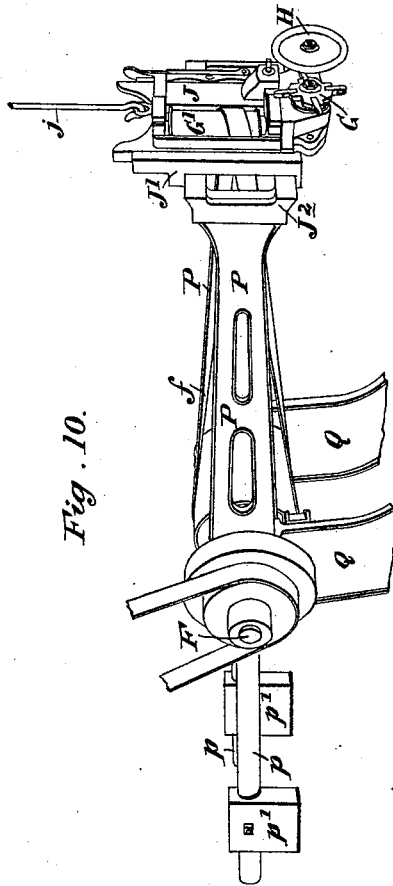

Fig. 10.

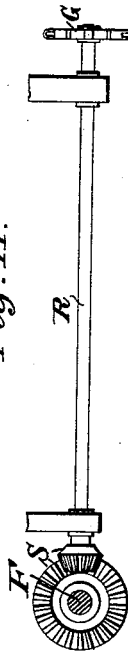

Fig. 11.

Witnesses
D. V. Bidgood,
Edward L. Cox

Inventor,
Daniel Fraser
By August 19 1895
Atty.

UNITED STATES PATENT OFFICE.

DANIEL FRASER, OF EDINBURGH, SCOTLAND, ASSIGNOR TO THE SCOTTISH GOLF CLUB MANUFACTURING COMPANY, LIMITED.

MACHINERY FOR SHAPING HEADS OF WOODEN CLUBS.

SPECIFICATION forming part of Letters Patent No. 542,246, dated July 9, 1895.

Application filed August 7, 1894. Serial No. 519,661. (No model.) Patented in England February 14, 1894, No. 3,169.

To all whom it may concern:

Be it known that I, DANIEL FRASER, gun and rifle manufacturer, of 4 Leith Street Terrace, Edinburgh, in the county of Mid-Lothian, Scotland, have invented Machinery for Shaping the Heads of Wooden Clubs Used in Playing the Game of Golf, (patented in Great Britain February 14, 1894, No. 3,169,) of which the following is a specification.

This invention relates to machinery for shaping the heads of wooden clubs used in playing the game of golf.

In accordance with my said invention the machine is provided with a metal pattern of the club-head required, from which pattern the cutter of the machine is guided, so that it automatically cuts out or shapes from the blank or block of the club-wood the exact shape of club-head required. Manual or skilled labor is thus dispensed with, and, further, the exact shape required is exactly obtained; also the shaping can be effected very much more rapidly than can be effected by hand-labor, so that the cost of production is very materially reduced.

In carrying out my invention I employ a suitable bed-plate and standards, after the manner of a metal-planing machine. The bed has mounted upon it a traveling table, which has two revolving spindles placed side by side, with a back center for each. Between the one spindle and its back center is placed the metal pattern. Between the other spindle and its back center is placed the club-head block. Above the said spindle carrying the metal pattern is a guide-wheel or tracer. Above the spindle carrying the club-head block is a revolving cutter. The said guide-wheel or tracer and revolving cutter are carried in the slides of a framing which is mounted above the bed-plate, the said slides being so mounted as to enable both a vertical and horizontal movement being given to the guide-wheel or tracer and revolving cutter.

In the drawings, Figures 1 and 2 are perspective views of my improved machine. Figs. 3 and 4 are elevation and side elevation, respectively, of the revolving cutter; and Fig. 5 is a view showing how the cutter is driven. Figs. 6 and 7 are elevation and plan, respectively, of a detail. Figs. 8 and 9 are elevation and plan, respectively, of a metal pattern from which the cutter is guided so as to produce the same pattern of a club-head upon

the required block of club-head wood. Fig. 10 is a part perspective view of a modification of said machine, and Fig. 11 is a modification of the cutter driving-gear.

Referring to the said drawings, I employ a bed-plate A having two or more standards a . On the top side of this bed-plate A, I mount a traveling table or bed B, which is formed with a head-stock b , into which is fitted the two horizontal spindles C D, said spindles being revolved by means of the slotted shaft E, which is driven by means of spur e and bevel-gearing e' from the main or driving shaft F of the machine—that is to say, I mount, by means of a feather, a spur-pinion e' on the said shaft E, said pinion being carried by a bracket b' on the under side of head-stock b and geared into the intermediate spur-pinion e^3 , which also gears with the spur-pinions c and d of the spindles C and D, the whole arrangement being such that no matter in what position the table or bed B is in the spindles C and D will be left free to revolve at equal speeds; so as to revolve the pattern and article being shaped at the same time.

The table B obtains its traveling motion from the main shaft F of the machine through the medium of the cross-shaft e^4 , spur e , bevel-reversing gear e^5 , and worm and worm-wheel arrangement B', said worm-wheel being keyed on the end of a small shaft, the inner end of which is provided with a small spur-pinion, which gears into a spur-rack attached to the under side of the table B in such a manner that on the reversing-gear e^5 being operated by means of the reversing-lever arrangement e^6 the table B will be reciprocated backward or forward, as the case may be.

In order to obtain an up-and-down movement for the revolving cutter G and guide-wheel H, so as to enable them to follow the shape of the pattern, I mount them adjustably in a vertical slide J, which works vertically in a horizontal slide J', carried by the uprights K of the machine in such a manner as to enable the cutter G and guide-wheel H to engage with the pattern and article being shaped by the weight of the vertical slide J and its connections, said slide J being provided with any suitable counterbalance-weight arrangement j or by means of a spiral or other spring arrangement acting either above or below the said slide J.

The revolving cutter G, (shown in detail,

Figs. 3 and 4,) is preferably formed with two, three, or more suitably-shaped knives g , which are secured to a central disk, said disk being connected to the one end of a spindle g' , Fig. 5, which has the bevel-pinion g^4 keyed on. Said pinion g^4 gears into a corresponding pinion g^3 , mounted on the lower end of an upright spindle g^3 , carried by the slide J, said spindle g^3 having a belt-pulley G' mounted on it, so as to enable the main shaft F of the machine to drive the cutter G by means of the belt f in such a manner as to impart a motion to the cutter G in a vertical and transverse direction to that of the revolving spindle C, between the grip C' and adjustable back center c' of which the article to be shaped is placed, the pattern being mounted between the end d' of the spindle D and adjustable back center d^2 in such a manner as to permit of the guide wheel H running freely over the surface of the pattern. The grip C' on the end of the spindle C is provided with two serrated or toothed jaws $c^3 c^3$, (shown in Figs. 6 and 7,) the top one c^3 of which is formed in the pivoted top portion of the grip, which can be bound in position when desired by means of the binding-screw c^4 . The lower jaw c^2 is also provided with a side-adjustment screw c^5 , so as to enable the work to be set as required. The back centers c' and d^2 are carried in the adjustable slides and screw-brackets b^2 , which work in slides in the table B, so as to permit of the centers c' and d^2 being adjusted.

In order that the traveling table or bed B may be traveled backward and forward by the operator, I provide the worm-wheel shaft with a friction-clutch hand wheel and lever arrangement B^2 , which when slackened out enables the spur-pinion to be turned so as to actuate the table B without interfering with any of the driving-gear.

In order to enable the machine to produce the desired shape of club-head, I employ a metal pattern L, as shown in Figs. 8 and 9, which, owing to its shape, together with the position of the center line l on which it revolves being equidistant from the outer extremities l' and l^2 of the head, gives sufficient strength and rigidity to the pattern and material, so as to enable the most delicately-shaped club-head or other like article being shaped or milled.

The pattern may be so formed as to represent any desired kind of golf-club head or the like.

The action of the foregoing machine is such that on the pattern L being placed and set between the spindle D and center d^2 , and the wood blank or block adjusted in and between the grip C' and center c' , the operator places the reversing-lever e^6 in position and starts the machine in motion by means of the starting-lever M, Fig. 1. This starting of the machine sets the spindles C and D and cutter G in motion, and owing to the guide-wheel or

tracer H moving freely on its center over and around the pattern L the cutter is caused to shape the article identical with the pattern L, after which all that requires to be done is to saw or otherwise cut off the ends or projections of the article corresponding to those marked l^3 and l^4 on the pattern.

As a modification I may arrange the machine as shown in Fig. 10—that is to say, in lieu of the uprights K of the machine for carrying the slides J and J', I employ a pivoted frame P, which may consist of one or two arms or brackets, the rear ends of which would be pivoted to the main driving-shaft F of the machine. The said frame P is provided beyond or behind the shaft F with one or more counterbalance-levers p and weights p' . The front end of the said frame P is attached to or provided with the cross-piece J^2 , on which the horizontal slide J' works, and the vertical slide J is made stationary, the movement being obtained by the oscillation of the said frame; or, as a further modification, I may dispense with the counterbalance-levers p and weights p' and form the arms or frame P in one piece with the brackets Q, which carry the main shaft F, or the arms P may be rigidly bolted to the said brackets Q.

In either of the foregoing cases I may employ a horizontal shaft R, Fig. 11, for driving the cutter G, said shaft R being carried by the frame P and driven by the main shaft F, through the medium of bevel-gearing S, in such a manner as to drive the cutter G at the required speed. The said cutter G may be mounted direct onto the end of the shaft R, as shown, or it may be connected and driven therefrom through the medium of spur-gearing. When the said shaft is used in combination with a solid frame—that is, with the arms or brackets P made in one with the brackets Q—I provide the said shaft R with a suitable universal or ball-and-socket joint and sliding tube, so as to permit of the up-and-down movement of the vertical slide J.

I claim—

In a lathe for turning irregular forms, the combination of a work holding spindle, a model holding spindle parallel thereto and geared to revolve at the same speed and in the same direction, a traversing frame carrying said spindle, a tool holder supported above said spindles, and having vertical and horizontal movement, a revolving cutter and a guide wheel carried by said holder on an axis parallel to said spindles, and means for revolving both spindles and the cutter, and for traversing said spindle carrying frame.

In testimony whereof I have signed my name to this specification in the presence of two subscribing witnesses.

DANL. FRASER.

Witnesses:

WILLIAM MILLER,
DAVID BEGG ROSS.